



ETA-Danmark A/S  
Göteborg Plads 1  
DK-2150 Nordhavn  
Tel. +45 72 24 59 00  
Fax +45 72 24 59 04  
Internet [www.etadanmark.dk](http://www.etadanmark.dk)

Authorised and notified according  
to Article 29 of the Regulation (EU)  
No 305/2011 of the European  
Parliament and of the Council of 9  
March 2011

MEMBER OF EOTA



## European Technical Assessment ETA-11/0469 of 2022/05/08

### I General Part

**Technical Assessment Body issuing the ETA and designated according to Article 29 of the Regulation (EU) No 305/2011: ETA-Danmark A/S**

**Trade name of the construction product:**

SkamoStructure Board 250

**Product family to which the above construction product belongs:**

Fire protective board

**Manufacturer:**

Skamol A/S  
Hasselager Centervej 1  
DK-8260 Viby  
Tel: +45 9772 1533  
Mail: [info@skamol.com](mailto:info@skamol.com)  
[www.skamol.com](http://www.skamol.com)

**Manufacturing plant:**

Skamol A/S  
Hasselager Centervej 1  
DK-8260 Viby

**This European Technical Assessment contains:**

23 pages including 2 annexes which form an integral part of the document

**This European Technical Assessment is issued in accordance with Regulation (EU) No 305/2011, on the basis of:**

European Assessment Document no. EAD 350142-00-1106 Fire protective board, slab and mat products and kits

**This version replaces:**

The ETA with the same number issued on 2018-06-27

Translations of this European Technical Assessment in other languages shall fully correspond to the original issued document and should be identified as such.

Communication of this European Technical Assessment, including transmission by electronic means, shall be in full (excepted the confidential Annex(es) referred to above). However, partial reproduction may be made, with the written consent of the issuing Technical Assessment Body. Any partial reproduction has to be identified as such.

## II SPECIFIC PART OF THE EUROPEAN TECHNICAL ASSESSMENT

### 1 Technical description of the product

#### Technical description of the product

The SkamoStructure Board 250 board is a lightweight calcium silicate board. The board is grey in appearance.

#### Dimensions and density

Dimensions and density of the board is given in table 1.

**Table 1: Dimensions and density**

Bulk density, dry: 250 kg/m <sup>3</sup>			
Tolerance on the length and width: ± 2,5 mm			
Tolerance on the thickness: ± 1,5 mm			
Length, mm	Width, mm	Thickness, mm	Weight kg pr. m <sup>2</sup>
1220	1000	22	5,50
1220	1000	25	6,25
1220	1000	30	7,50
1220	1000	35	8,75
1220	1000	40	10,00
1220	1000	45	11,25
1220	1000	47	11,75
1220	1000	50	12,50
1220	1000	55	13,75
1220	1000	60	15,00
2040	1220	22	5,50
2040	1220	25	6,25
2040	1220	30	7,50
2040	1220	35	8,75
2040	1220	40	10,00
2040	1220	45	11,25
2040	1220	47	11,75
2040	1220	50	12,50
2040	1220	55	13,75
2040	1220	60	15,00

#### Ancillary products

The is ETA covers the board alone. Ancillary products referred to in this ETA, as a part of installation provisions or in the framework of determining performances (e.g. fire resistance test), are not covered by this ETA and cannot be CE marked on the basis of it.

### 2 Specification of the intended use in accordance with the applicable European Assessment Document (hereinafter EAD)

The intended use of the board is internal use designated as type Y in EAD 350142-00-1106.

The board is intended to protect elements to be used in assemblies as specified in table 2:

**Table 2: Intended use**

Protection of	EAD 350142-00-1106 reference	Assessment within the framework of this ETA
Fire protective products as horizontal membrane protection	Type 1	No
Fire protective products as vertical membrane protection	Type 2	No
Load bearing concrete elements	Type 3	No
Load bearing steel elements	Type 4	Load bearing steel beam and column protection
Load bearing flat concrete profiles sheet composite elements	Type 5	No
Load bearing concrete filled hollow steel elements	Type 6	No
Load bearing timber elements	Type 7	No
Fire separating assemblies with no load bearing requirements	Type 8	No
Technical services in buildings	Type 9	No
Uses not covered by type 1-9	Type 10	No

Table 1 shows the possible intended uses of the boards. Not all of these have been assessed within the framework of this ETA with regard to fire resistance performance. Annex 2 shows a list of the uses for which fire resistance assessment was carried out. This ETA covers assemblies installed in accordance with the provisions given in Annex 2.

The provisions made in this European Technical Assessment are based on an assumed intended working life of the boards of 25 years.

The indications given on the working life cannot be interpreted as a guarantee given by the producer or Assessment Body, but are to be regarded only as a means for choosing the right products in relation to the expected economically reasonable working life of the works.

### 3 Performance of the product and references to the methods used for its assessment

---

#### Characteristic

#### Assessment of characteristic

#### 3.2 Safety in case of fire (BWR2)

Reaction to fire

SkamoStructure Board 250 are classified as Euroclass A1 in accordance with EN 13501-1 and Commission Delegated Regulation 2016/364

Resistance to fire

The design charts for determining the resistance to fire performance according to EN 13501-2 is presented in annex 2.

#### 3.3 Hygiene, health and the environment (BWR3)

Content, emission and/or release of dangerous substances

No performance assessed

Air and water permeability

This characteristic is not relevant for the intended use Z<sub>2</sub> (internal use)

#### 3.4 Safety in use (BWR 4)

Flexural strength

The declared MOR for the board is 1,0 MPa.

The boards have sufficient strength to support their own mass. The boards are not intended to support additional loads.

Dimensional stability

The boards, tested in accordance with EN 1604, are dimensionally stable.

#### 3.6 Energy economy and heat retention (BRW 6)

Thermal conductivity

The declared  $\lambda_{10}$ -value for a board with density 250 kg/m<sup>3</sup> is 0,073 W/mK

Water vapour permeability

No performance assessed

#### 3.7 Sustainable use of natural resources (BWR7)

No performance assessed

#### 3.8 General aspects related to the performance of the product

Resistance to deterioration caused by water

This characteristic is not relevant to the intended use Z<sub>2</sub> if no more than accidental wetting is expected.

Resistance soak/dry

This characteristic is not relevant for the intended use Z<sub>2</sub> (internal use)

Resistance to freeze/thaw

Use category Y in accordance with EAD 350142-00-1106

---

Characteristic	Assessment of characteristic
Resistance to heat/rain	This characteristic is not relevant for the intended use Z <sub>2</sub> (internal use)
Basic durability assessment	Product performances of the boards covered by this ETA confirm a working life of 25 years for the intended use type Y (internal and semi-exposed use) and Z <sub>2</sub> (internal use if no more than accidental wetting inside the building is to be expected)
Compressive strength	The board have a compressive strength of 2,8 MPa

\*) In addition to the specific clauses relating to dangerous substances contained in this European technical Assessment, there may be other requirements applicable to the products falling within its scope (e.g. transposed European legislation and national laws, regulations and administrative provisions). In order to meet the provisions of the Construction Products Regulation, these requirements need also to be complied with, when and where they apply.

### **3.10 Aspects related to the performance of the product**

#### Cutting and machining

The fire protective boards shall be cut and machined using conventional woodworking equipment. The use of saw blades with hardened teeth or with tungsten carbide tipped blades is recommended. When machining the fire protective board with power tools, dust extraction shall take place and inhalation of dust should be avoided.

A safety data sheet is available from the manufacturer upon request.

#### Joints

The fire protective boards shall be butt jointed. The boards can have square or beveled edges. The type of edge shall be in accordance with the assemblies described in annex 1.

Joints in adjacent boards, where possible, shall be staggered over a minimum distance of 300 mm.

#### Mechanical fasteners

Fastening of the fire protective boards onto the support structure shall be in accordance with the assembly information provided in annex 1.

#### Surface treatment

The board surface allows most types of decoration.

When applying a surface treatment, the absorption capacity and alkalinity of the boards have to be taken into account.

Assessment of the influence of surface treatment (such as plastering, paints, tiles, wallpaper), on the performance of the boards, has not been performed in the framework of this ETA.

#### Assembly

The boards shall be applied as specified in the assemblies in annex 1.

## **4 Attestation and verification of constancy of performance (AVCP)**

### **4.1 AVCP system**

According to the decision 99/454/EC of the European Commission<sup>1</sup>, as amended, the system(s) of assessment and verification of constancy of performance (see Annex V to Regulation (EU) No 305/2011) is 1.

## **5 Technical details necessary for the implementation of the AVCP system, as foreseen in the applicable EAD**

Technical details necessary for the implementation of the AVCP system are laid down in the control plan deposited at ETA-Danmark prior to CE marking.

Issued in Copenhagen on 2022-05-08 by



Thomas Bruun  
Managing Director, ETA-Danmark



**Annex 1  
Assembly**

**Assembly of SkamoStructure Board 250 to closed steel sections**

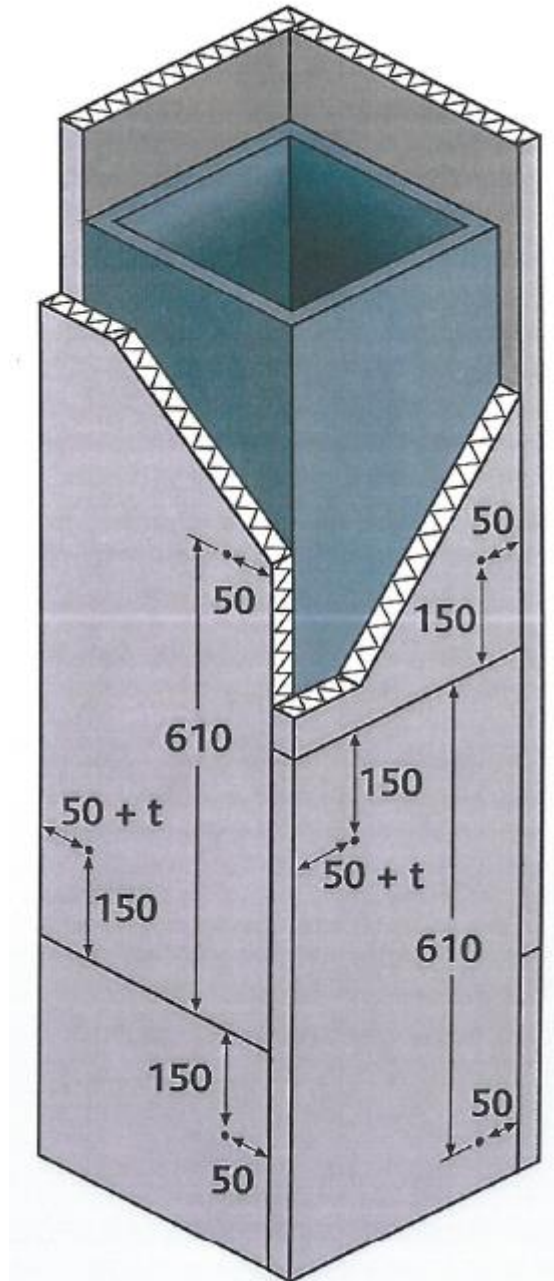

Figure A.1 Position of shot nails in closed profiled steel – four sided protection

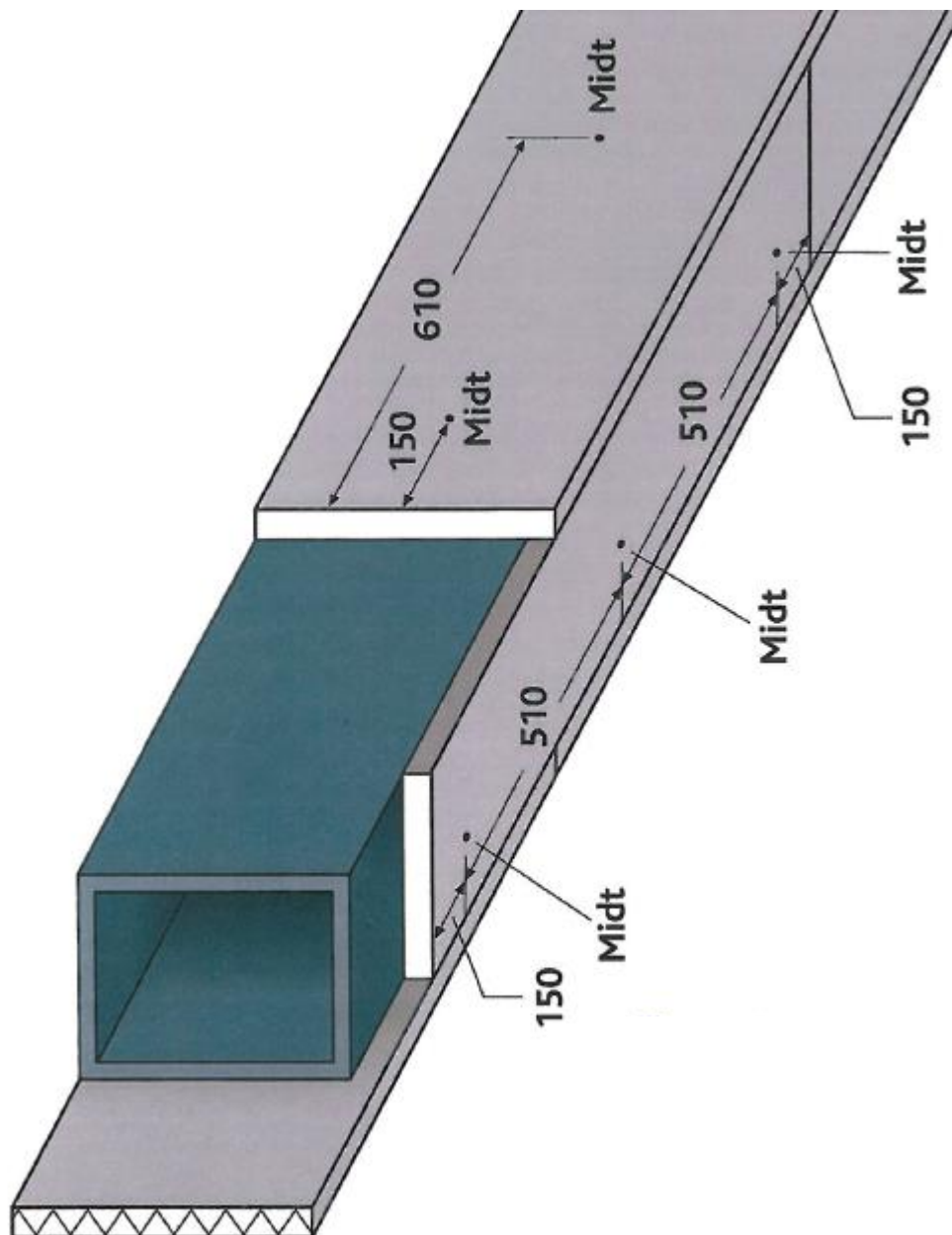

Figure A.2 Position of shot nails in closed profiled steel – three sided  
Shot nails length 37 mm with Ø30 mm washer used for 25 mm fire protection  
Shot nails length 62 mm with Ø30 mm washer used for 50 mm fire protection  
Midt = centre

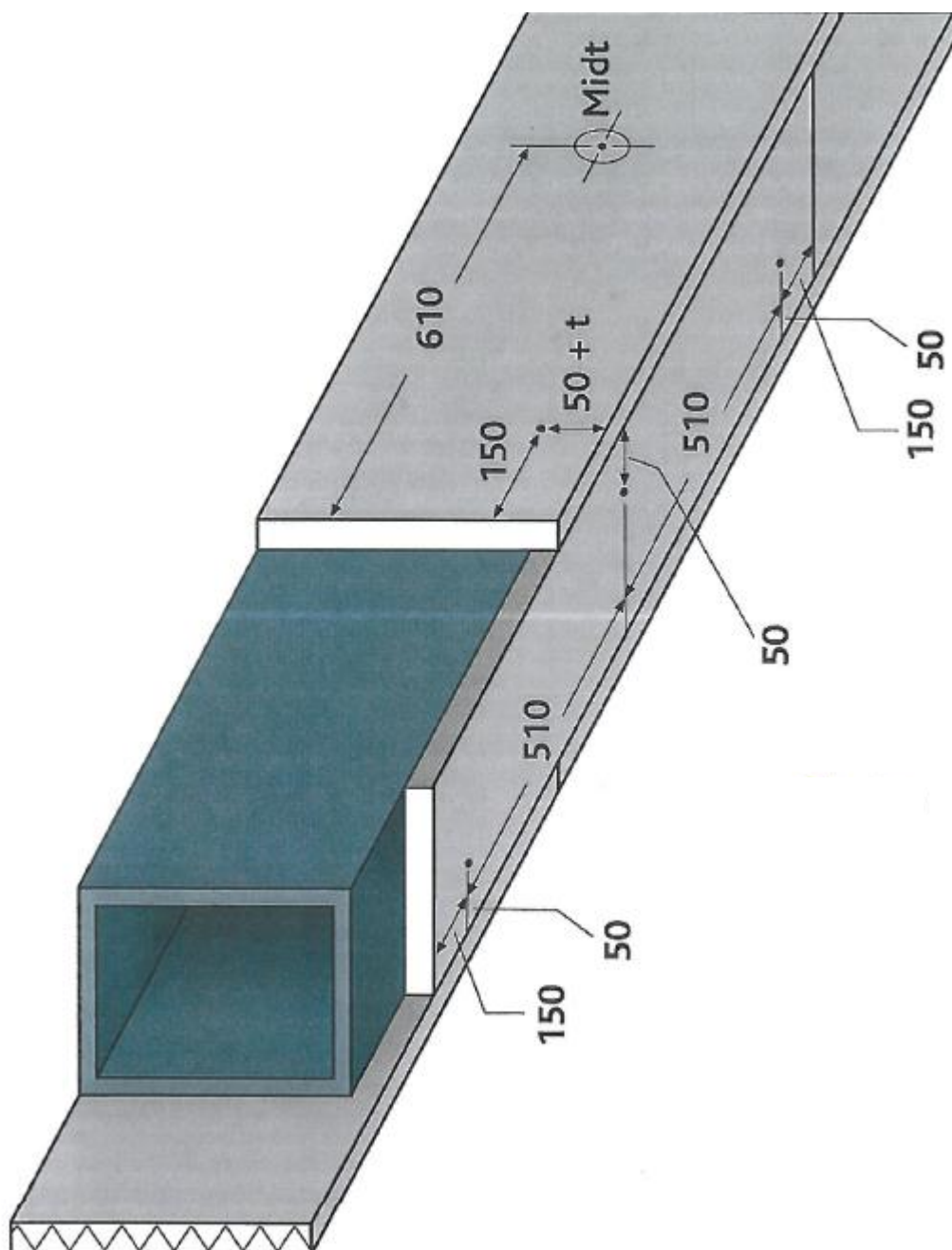

Figure A.3 Position of shot nails in closed profiled steel – three sided  
Shot nails length 37 mm with  $\text{Ø}30$  mm washer used for 25 mm fire protection  
Shot nails length 62 mm with  $\text{Ø}30$  mm washer used for 50 mm fire protection  
Midt = centre

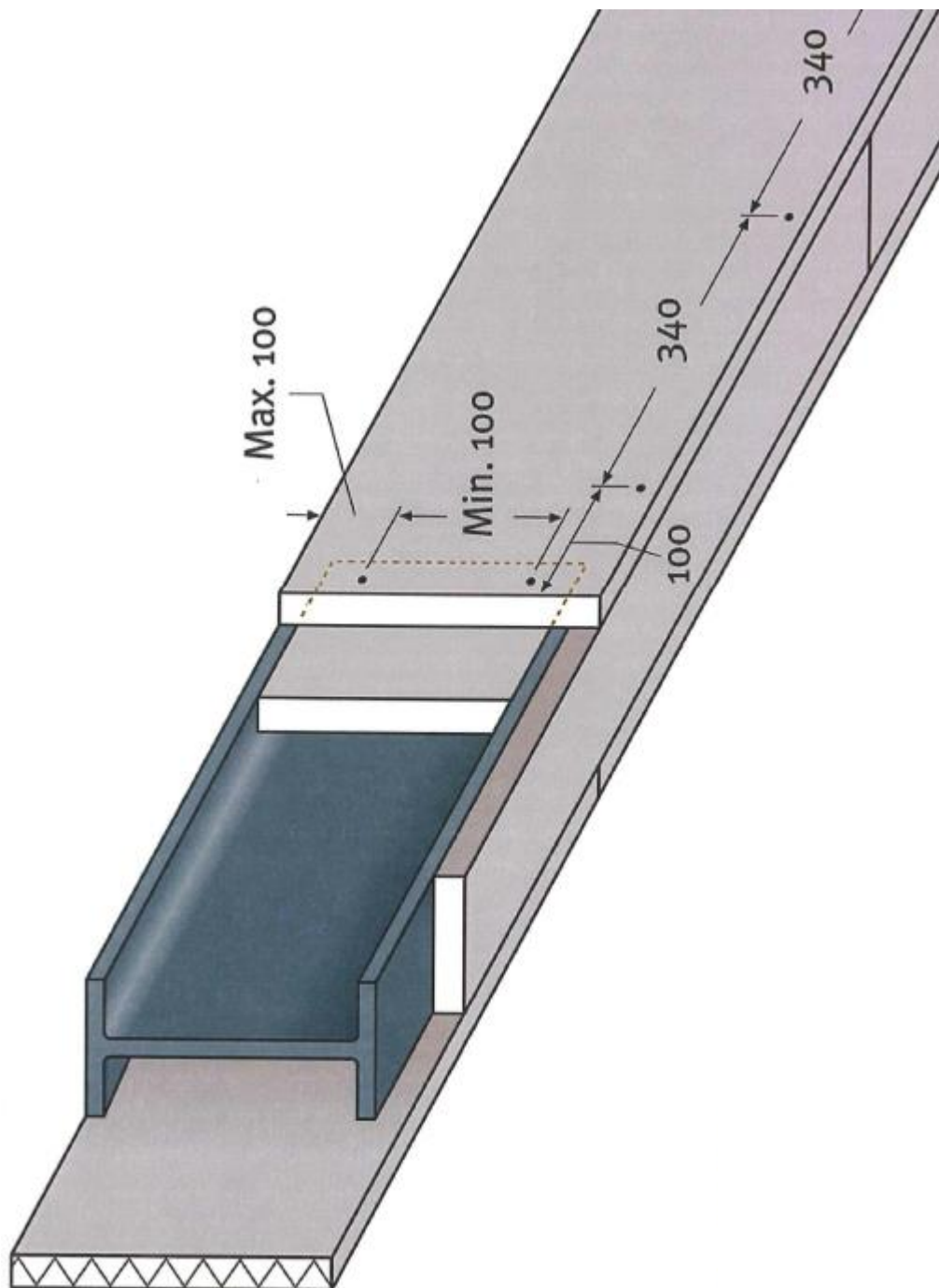

Figure A.4 Position of screws in open profiled steel – three sided  
Screws  $3,8 \times 45$  mm used for 25 mm fire protection  
Screws  $5,0 \times 90$  mm used for 50 mm fire protection

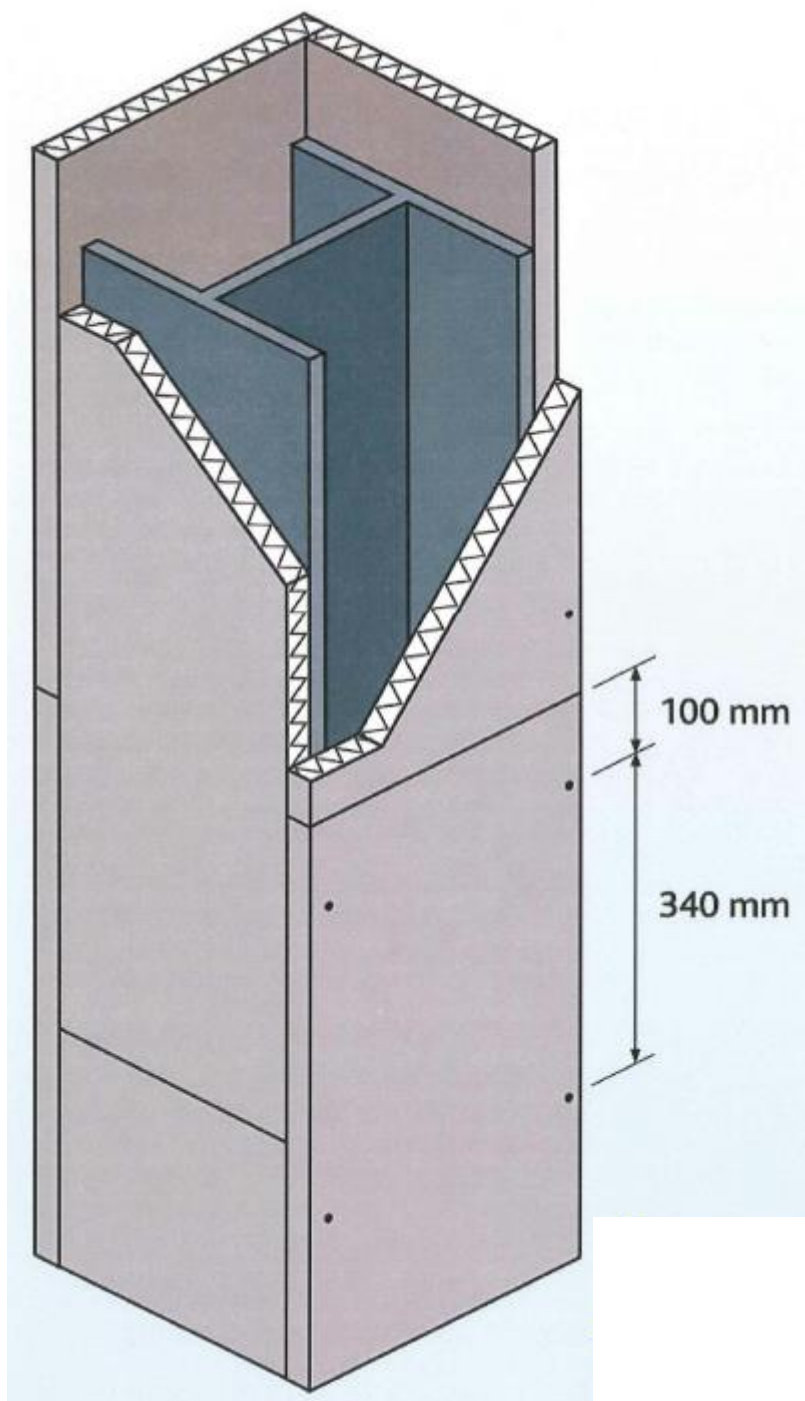

Figure A.5 Position of screws in open profiled steel – four sided  
Screws  $3,8 \times 45$  mm used for 25 mm fire protection  
Screws  $5,0 \times 90$  mm used for 50 mm fire protection

**Annex 2**  
**Design charts**

30 minutes	Design temperature								
	350°C	400°C	450°C	500°C	550°C	600°C	650°C	700°C	750°C
Am/V	Minimum thicknesses [mm]								
60	25,0	25,0	25,0	25,0	25,0	25,0	25,0	25,0	25,0
65	25,0	25,0	25,0	25,0	25,0	25,0	25,0	25,0	25,0
70	25,0	25,0	25,0	25,0	25,0	25,0	25,0	25,0	25,0
75	25,0	25,0	25,0	25,0	25,0	25,0	25,0	25,0	25,0
80	25,0	25,0	25,0	25,0	25,0	25,0	25,0	25,0	25,0
85	25,0	25,0	25,0	25,0	25,0	25,0	25,0	25,0	25,0
90	25,0	25,0	25,0	25,0	25,0	25,0	25,0	25,0	25,0
95	25,0	25,0	25,0	25,0	25,0	25,0	25,0	25,0	25,0
100	25,0	25,0	25,0	25,0	25,0	25,0	25,0	25,0	25,0
105	25,0	25,0	25,0	25,0	25,0	25,0	25,0	25,0	25,0
110	25,0	25,0	25,0	25,0	25,0	25,0	25,0	25,0	25,0
115	25,0	25,0	25,0	25,0	25,0	25,0	25,0	25,0	25,0
120	25,0	25,0	25,0	25,0	25,0	25,0	25,0	25,0	25,0
125	25,0	25,0	25,0	25,0	25,0	25,0	25,0	25,0	25,0
130	25,0	25,0	25,0	25,0	25,0	25,0	25,0	25,0	25,0
135	25,0	25,0	25,0	25,0	25,0	25,0	25,0	25,0	25,0
140	25,0	25,0	25,0	25,0	25,0	25,0	25,0	25,0	25,0
145	25,0	25,0	25,0	25,0	25,0	25,0	25,0	25,0	25,0
150	25,0	25,0	25,0	25,0	25,0	25,0	25,0	25,0	25,0
155	25,0	25,0	25,0	25,0	25,0	25,0	25,0	25,0	25,0
160	25,0	25,0	25,0	25,0	25,0	25,0	25,0	25,0	25,0
165	25,0	25,0	25,0	25,0	25,0	25,0	25,0	25,0	25,0
170	25,0	25,0	25,0	25,0	25,0	25,0	25,0	25,0	25,0
175	25,0	25,0	25,0	25,0	25,0	25,0	25,0	25,0	25,0
180	25,0	25,0	25,0	25,0	25,0	25,0	25,0	25,0	25,0
185	25,0	25,0	25,0	25,0	25,0	25,0	25,0	25,0	25,0
190	25,0	25,0	25,0	25,0	25,0	25,0	25,0	25,0	25,0
195	25,0	25,0	25,0	25,0	25,0	25,0	25,0	25,0	25,0
200	25,0	25,0	25,0	25,0	25,0	25,0	25,0	25,0	25,0
205	25,0	25,0	25,0	25,0	25,0	25,0	25,0	25,0	25,0
210	25,0	25,0	25,0	25,0	25,0	25,0	25,0	25,0	25,0
215	25,0	25,0	25,0	25,0	25,0	25,0	25,0	25,0	25,0
220	25,0	25,0	25,0	25,0	25,0	25,0	25,0	25,0	25,0
225	25,0	25,0	25,0	25,0	25,0	25,0	25,0	25,0	25,0
230	25,0	25,0	25,0	25,0	25,0	25,0	25,0	25,0	25,0
235	25,0	25,0	25,0	25,0	25,0	25,0	25,0	25,0	25,0
240	30,0	25,0	25,0	25,0	25,0	25,0	25,0	25,0	25,0
245	30,0	25,0	25,0	25,0	25,0	25,0	25,0	25,0	25,0
250	30,0	25,0	25,0	25,0	25,0	25,0	25,0	25,0	25,0
255	30,0	25,0	25,0	25,0	25,0	25,0	25,0	25,0	25,0
260	30,0	25,0	25,0	25,0	25,0	25,0	25,0	25,0	25,0
265	30,0	25,0	25,0	25,0	25,0	25,0	25,0	25,0	25,0
270	30,0	25,0	25,0	25,0	25,0	25,0	25,0	25,0	25,0
275	30,0	25,0	25,0	25,0	25,0	25,0	25,0	25,0	25,0
280	30,0	25,0	25,0	25,0	25,0	25,0	25,0	25,0	25,0
285	30,0	25,0	25,0	25,0	25,0	25,0	25,0	25,0	25,0
290	30,0	25,0	25,0	25,0	25,0	25,0	25,0	25,0	25,0

Table B.1 30 minute fire resistance closed profiles

60 minutes	Design temperature								
	350°C	400°C	450°C	500°C	550°C	600°C	650°C	700°C	750°C
Am/V	Minimum thicknesses [mm]								
60	25,0	25,0	25,0	25,0	25,0	25,0	25,0	25,0	25,0
65	25,0	25,0	25,0	25,0	25,0	25,0	25,0	25,0	25,0
70	30,0	25,0	25,0	25,0	25,0	25,0	25,0	25,0	25,0
75	30,0	25,0	25,0	25,0	25,0	25,0	25,0	25,0	25,0
80	30,0	25,0	25,0	25,0	25,0	25,0	25,0	25,0	25,0
85	30,0	25,0	25,0	25,0	25,0	25,0	25,0	25,0	25,0
90	30,0	25,0	25,0	25,0	25,0	25,0	25,0	25,0	25,0
95	30,0	25,0	25,0	25,0	25,0	25,0	25,0	25,0	25,0
100	30,0	30,0	25,0	25,0	25,0	25,0	25,0	25,0	25,0
105	30,0	30,0	25,0	25,0	25,0	25,0	25,0	25,0	25,0
110	30,0	30,0	25,0	25,0	25,0	25,0	25,0	25,0	25,0
115	35,0	30,0	25,0	25,0	25,0	25,0	25,0	25,0	25,0
120	35,0	30,0	25,0	25,0	25,0	25,0	25,0	25,0	25,0
125	35,0	30,0	25,0	25,0	25,0	25,0	25,0	25,0	25,0
130	35,0	30,0	25,0	25,0	25,0	25,0	25,0	25,0	25,0
135	35,0	30,0	30,0	25,0	25,0	25,0	25,0	25,0	25,0
140	35,0	30,0	30,0	25,0	25,0	25,0	25,0	25,0	25,0
145	35,0	30,0	30,0	25,0	25,0	25,0	25,0	25,0	25,0
150	35,0	35,0	30,0	25,0	25,0	25,0	25,0	25,0	25,0
155	35,0	35,0	30,0	25,0	25,0	25,0	25,0	25,0	25,0
160	40,0	35,0	30,0	25,0	25,0	25,0	25,0	25,0	25,0
165	40,0	35,0	30,0	25,0	25,0	25,0	25,0	25,0	25,0
170	40,0	35,0	30,0	25,0	25,0	25,0	25,0	25,0	25,0
175	40,0	35,0	30,0	25,0	25,0	25,0	25,0	25,0	25,0
180	40,0	35,0	30,0	25,0	25,0	25,0	25,0	25,0	25,0
185	40,0	35,0	30,0	25,0	25,0	25,0	25,0	25,0	25,0
190	40,0	35,0	30,0	30,0	25,0	25,0	25,0	25,0	25,0
195	40,0	35,0	30,0	30,0	25,0	25,0	25,0	25,0	25,0
200	40,0	35,0	30,0	30,0	25,0	25,0	25,0	25,0	25,0
205	45,0	35,0	35,0	30,0	25,0	25,0	25,0	25,0	25,0
210	45,0	40,0	35,0	30,0	25,0	25,0	25,0	25,0	25,0
215	45,0	40,0	35,0	30,0	25,0	25,0	25,0	25,0	25,0
220	45,0	40,0	35,0	30,0	25,0	25,0	25,0	25,0	25,0
225	45,0	40,0	35,0	30,0	25,0	25,0	25,0	25,0	25,0
230	45,0	40,0	35,0	30,0	25,0	25,0	25,0	25,0	25,0
235	45,0	40,0	35,0	30,0	25,0	25,0	25,0	25,0	25,0
240	45,0	40,0	35,0	30,0	25,0	25,0	25,0	25,0	25,0
245	45,0	40,0	35,0	30,0	25,0	25,0	25,0	25,0	25,0
250	45,0	40,0	35,0	30,0	25,0	25,0	25,0	25,0	25,0
255	45,0	40,0	35,0	30,0	25,0	25,0	25,0	25,0	25,0
260	50,0	40,0	35,0	30,0	25,0	25,0	25,0	25,0	25,0
265	50,0	40,0	35,0	30,0	25,0	25,0	25,0	25,0	25,0
270	50,0	40,0	35,0	30,0	25,0	25,0	25,0	25,0	25,0
275	50,0	40,0	35,0	30,0	30,0	25,0	25,0	25,0	25,0
280	50,0	40,0	35,0	30,0	30,0	25,0	25,0	25,0	25,0
285	50,0	45,0	35,0	30,0	30,0	25,0	25,0	25,0	25,0
290	50,0	45,0	35,0	30,0	30,0	25,0	25,0	25,0	25,0

Table B.2 60 minutes fire resistance closed profiles

90 minutes	Design temperature								
	350°C	400°C	450°C	500°C	550°C	600°C	650°C	700°C	750°C
Am/V	Minimum thicknesses [mm]								
60	30,0	30,0	25,0	25,0	25,0	25,0	25,0	25,0	25,0
65	35,0	30,0	25,0	25,0	25,0	25,0	25,0	25,0	25,0
70	35,0	30,0	30,0	25,0	25,0	25,0	25,0	25,0	25,0
75	35,0	30,0	30,0	25,0	25,0	25,0	25,0	25,0	25,0
80	35,0	35,0	30,0	25,0	25,0	25,0	25,0	25,0	25,0
85	35,0	35,0	30,0	30,0	25,0	25,0	25,0	25,0	25,0
90	40,0	35,0	30,0	30,0	25,0	25,0	25,0	25,0	25,0
95	40,0	35,0	30,0	30,0	25,0	25,0	25,0	25,0	25,0
100	40,0	35,0	35,0	30,0	25,0	25,0	25,0	25,0	25,0
105	40,0	35,0	35,0	30,0	25,0	25,0	25,0	25,0	25,0
110	40,0	40,0	35,0	30,0	30,0	25,0	25,0	25,0	25,0
115	45,0	40,0	35,0	30,0	30,0	25,0	25,0	25,0	25,0
120	45,0	40,0	35,0	30,0	30,0	25,0	25,0	25,0	25,0
125	45,0	40,0	35,0	35,0	30,0	25,0	25,0	25,0	25,0
130	45,0	40,0	35,0	35,0	30,0	25,0	25,0	25,0	25,0
135	45,0	40,0	40,0	35,0	30,0	30,0	25,0	25,0	25,0
140	45,0	45,0	40,0	35,0	30,0	30,0	25,0	25,0	25,0
145	50,0	45,0	40,0	35,0	30,0	30,0	25,0	25,0	25,0
150	50,0	45,0	40,0	35,0	30,0	30,0	25,0	25,0	25,0
155	50,0	45,0	40,0	35,0	35,0	30,0	25,0	25,0	25,0
160	50,0	45,0	40,0	35,0	35,0	30,0	25,0	25,0	25,0
165	50,0	45,0	40,0	40,0	35,0	30,0	25,0	25,0	25,0
170	55,0	45,0	40,0	40,0	35,0	30,0	30,0	25,0	25,0
175	55,0	50,0	45,0	40,0	35,0	30,0	30,0	25,0	25,0
180	55,0	50,0	45,0	40,0	35,0	30,0	30,0	25,0	25,0
185		50,0	45,0	40,0	35,0	30,0	30,0	25,0	25,0
190		50,0	45,0	40,0	35,0	30,0	30,0	25,0	25,0
195		50,0	45,0	40,0	35,0	35,0	30,0	25,0	25,0
200		50,0	45,0	40,0	35,0	35,0	30,0	25,0	25,0
205		50,0	45,0	40,0	35,0	35,0	30,0	25,0	25,0
210		55,0	45,0	40,0	40,0	35,0	30,0	25,0	25,0
215		55,0	45,0	40,0	40,0	35,0	30,0	25,0	25,0
220		55,0	50,0	45,0	40,0	35,0	30,0	30,0	25,0
225		55,0	50,0	45,0	40,0	35,0	30,0	30,0	25,0
230			50,0	45,0	40,0	35,0	30,0	30,0	25,0
235			50,0	45,0	40,0	35,0	30,0	30,0	25,0
240			50,0	45,0	40,0	35,0	30,0	30,0	25,0
245			50,0	45,0	40,0	35,0	30,0	30,0	25,0
250			50,0	45,0	40,0	35,0	30,0	30,0	25,0
255			50,0	45,0	40,0	35,0	30,0	30,0	25,0
260			50,0	45,0	40,0	35,0	35,0	30,0	25,0
265			50,0	45,0	40,0	35,0	35,0	30,0	25,0
270			55,0	45,0	40,0	35,0	35,0	30,0	25,0
275			55,0	45,0	40,0	35,0	35,0	30,0	25,0
280			55,0	45,0	40,0	40,0	35,0	30,0	25,0
285			55,0	50,0	40,0	40,0	35,0	30,0	25,0
290			55,0	50,0	45,0	40,0	35,0	30,0	25,0

Table B.3 90 minutes fire resistance closed profiles



120 minutes	Design temperature								
	350°C	400°C	450°C	500°C	550°C	600°C	650°C	700°C	750°C
Am/V	Minimum thicknesses [mm]								
60	35,0	35,0	30,0	30,0	25,0	25,0	25,0	25,0	25,0
65	40,0	35,0	35,0	30,0	25,0	25,0	25,0	25,0	25,0
70	40,0	35,0	35,0	30,0	30,0	25,0	25,0	25,0	25,0
75	40,0	40,0	35,0	30,0	30,0	25,0	25,0	25,0	25,0
80	45,0	40,0	35,0	35,0	30,0	30,0	25,0	25,0	25,0
85	45,0	40,0	40,0	35,0	30,0	30,0	25,0	25,0	25,0
90	45,0	40,0	40,0	35,0	35,0	30,0	25,0	25,0	25,0
95	45,0	45,0	40,0	35,0	35,0	30,0	30,0	25,0	25,0
100	50,0	45,0	40,0	40,0	35,0	30,0	30,0	25,0	25,0
105	50,0	45,0	40,0	40,0	35,0	30,0	30,0	25,0	25,0
110	50,0	45,0	45,0	40,0	35,0	35,0	30,0	25,0	25,0
115	50,0	50,0	45,0	40,0	35,0	35,0	30,0	30,0	25,0
120	55,0	50,0	45,0	40,0	40,0	35,0	30,0	30,0	25,0
125		50,0	45,0	40,0	40,0	35,0	30,0	30,0	25,0
130		50,0	45,0	45,0	40,0	35,0	35,0	30,0	25,0
135		55,0	50,0	45,0	40,0	35,0	35,0	30,0	30,0
140		55,0	50,0	45,0	40,0	35,0	35,0	30,0	30,0
145		55,0	50,0	45,0	40,0	40,0	35,0	30,0	30,0
150			50,0	45,0	45,0	40,0	35,0	30,0	30,0
155			50,0	45,0	45,0	40,0	35,0	35,0	30,0
160			55,0	50,0	45,0	40,0	35,0	35,0	30,0
165			55,0	50,0	45,0	40,0	35,0	35,0	30,0
170			55,0	50,0	45,0	40,0	40,0	35,0	30,0
175				50,0	45,0	40,0	40,0	35,0	30,0
180				50,0	45,0	40,0	40,0	35,0	30,0
185				50,0	45,0	45,0	40,0	35,0	30,0
190				50,0	50,0	45,0	40,0	35,0	35,0
195				55,0	50,0	45,0	40,0	35,0	35,0
200				55,0	50,0	45,0	40,0	35,0	35,0
205				55,0	50,0	45,0	40,0	35,0	35,0
210					50,0	45,0	40,0	35,0	35,0
215					50,0	45,0	40,0	40,0	35,0
220					50,0	45,0	40,0	40,0	35,0
225					50,0	45,0	40,0	40,0	35,0
230					50,0	45,0	45,0	40,0	35,0
235					50,0	45,0	45,0	40,0	35,0
240					55,0	50,0	45,0	40,0	35,0
245					55,0	50,0	45,0	40,0	35,0
250					55,0	50,0	45,0	40,0	35,0
255					55,0	50,0	45,0	40,0	35,0
260					55,0	50,0	45,0	40,0	35,0
265						50,0	45,0	40,0	35,0
270						50,0	45,0	40,0	40,0
275						50,0	45,0	40,0	40,0
280						50,0	45,0	40,0	40,0
285						50,0	45,0	40,0	40,0
290						50,0	45,0	40,0	40,0

Table B.4 120 minutes fire resistance closed profiles

180 minutes	Design temperature								
	350°C	400°C	450°C	500°C	550°C	600°C	650°C	700°C	750°C
Am/V	Minimum thicknesses [mm]								
60	50,0	45,0	40,0	40,0	35,0	35,0	30,0	30,0	25,0
65	50,0	45,0	45,0	40,0	40,0	35,0	35,0	30,0	30,0
70	50,0	50,0	45,0	45,0	40,0	35,0	35,0	30,0	30,0
75	55,0	50,0	50,0	45,0	40,0	40,0	35,0	35,0	30,0
80		55,0	50,0	45,0	45,0	40,0	40,0	35,0	30,0
85			50,0	50,0	45,0	40,0	40,0	35,0	35,0
90			55,0	50,0	45,0	45,0	40,0	40,0	35,0
95				50,0	50,0	45,0	40,0	40,0	35,0
100				55,0	50,0	45,0	45,0	40,0	35,0
105					50,0	50,0	45,0	40,0	40,0
110					55,0	50,0	45,0	40,0	40,0
115					55,0	50,0	45,0	45,0	40,0
120						50,0	50,0	45,0	40,0
125						55,0	50,0	45,0	40,0
130						55,0	50,0	45,0	45,0
135							50,0	45,0	45,0
140							50,0	50,0	45,0
145							55,0	50,0	45,0
150							55,0	50,0	45,0
155							55,0	50,0	45,0
160								50,0	50,0
165								50,0	50,0
170								55,0	50,0
175								55,0	50,0
180								55,0	50,0
185									50,0
190									50,0
195									50,0
200									55,0
205									55,0
210									55,0
215									55,0
220									
225									
230									
235									
240									
245									
250									
255									
260									
265									
270									
275									
280									
285									
290									

Table B.5 180 minutes fire resistance closed profiles

30 minutes	Design temperature						
	350°C	400°C	450°C	500°C	550°C	600°C	650°C
Am/V	Minimum thicknesses [mm]						
40	22,0	22,0	22,0	22,0	22,0	22,0	22,0
45	22,0	22,0	22,0	22,0	22,0	22,0	22,0
50	22,0	22,0	22,0	22,0	22,0	22,0	22,0
55	22,0	22,0	22,0	22,0	22,0	22,0	22,0
60	22,0	22,0	22,0	22,0	22,0	22,0	22,0
65	22,0	22,0	22,0	22,0	22,0	22,0	22,0
70	22,0	22,0	22,0	22,0	22,0	22,0	22,0
75	22,0	22,0	22,0	22,0	22,0	22,0	22,0
80	22,0	22,0	22,0	22,0	22,0	22,0	22,0
85	22,0	22,0	22,0	22,0	22,0	22,0	22,0
90	22,0	22,0	22,0	22,0	22,0	22,0	22,0
95	22,0	22,0	22,0	22,0	22,0	22,0	22,0
100	22,0	22,0	22,0	22,0	22,0	22,0	22,0
105	22,0	22,0	22,0	22,0	22,0	22,0	22,0
110	22,0	22,0	22,0	22,0	22,0	22,0	22,0
115	22,0	22,0	22,0	22,0	22,0	22,0	22,0
120	22,0	22,0	22,0	22,0	22,0	22,0	22,0
125	22,0	22,0	22,0	22,0	22,0	22,0	22,0
130	22,0	22,0	22,0	22,0	22,0	22,0	22,0
135	22,0	22,0	22,0	22,0	22,0	22,0	22,0
140	22,0	22,0	22,0	22,0	22,0	22,0	22,0
145	22,0	22,0	22,0	22,0	22,0	22,0	22,0
150	22,0	22,0	22,0	22,0	22,0	22,0	22,0
155	22,0	22,0	22,0	22,0	22,0	22,0	22,0
160	22,0	22,0	22,0	22,0	22,0	22,0	22,0
165	22,0	22,0	22,0	22,0	22,0	22,0	22,0
170	22,0	22,0	22,0	22,0	22,0	22,0	22,0
175	22,0	22,0	22,0	22,0	22,0	22,0	22,0
180	22,0	22,0	22,0	22,0	22,0	22,0	22,0
185	22,0	22,0	22,0	22,0	22,0	22,0	22,0
190	22,0	22,0	22,0	22,0	22,0	22,0	22,0
195	22,0	22,0	22,0	22,0	22,0	22,0	22,0
200	22,0	22,0	22,0	22,0	22,0	22,0	22,0
205	22,0	22,0	22,0	22,0	22,0	22,0	22,0
210	22,0	22,0	22,0	22,0	22,0	22,0	22,0
215	22,0	22,0	22,0	22,0	22,0	22,0	22,0
220	22,0	22,0	22,0	22,0	22,0	22,0	22,0
225	22,0	22,0	22,0	22,0	22,0	22,0	22,0
230	22,0	22,0	22,0	22,0	22,0	22,0	22,0
235	22,0	22,0	22,0	22,0	22,0	22,0	22,0
240	22,0	22,0	22,0	22,0	22,0	22,0	22,0
245	22,0	22,0	22,0	22,0	22,0	22,0	22,0
250	22,0	22,0	22,0	22,0	22,0	22,0	22,0
255	22,0	22,0	22,0	22,0	22,0	22,0	22,0
260	22,0	22,0	22,0	22,0	22,0	22,0	22,0
265	22,0	22,0	22,0	22,0	22,0	22,0	22,0
270	22,0	22,0	22,0	22,0	22,0	22,0	22,0
275	22,0	22,0	22,0	22,0	22,0	22,0	22,0
280	22,0	22,0	22,0	22,0	22,0	22,0	22,0
285	22,0	22,0	22,0	22,0	22,0	22,0	22,0
290	22,0	22,0	22,0	22,0	22,0	22,0	22,0
295	22,0	22,0	22,0	22,0	22,0	22,0	22,0
300	22,0	22,0	22,0	22,0	22,0	22,0	22,0
330	22,0	22,0	22,0	22,0	22,0	22,0	22,0
400	30,0	25,0	22,0	22,0	22,0	22,0	22,0

Table B.6 30 minutes fire resistance open profiles

60 minutes	Design temperature						
	350°C	400°C	450°C	500°C	550°C	600°C	650°C
Am/V	Minimum thicknesses [mm]						
40	22,0	22,0	22,0	22,0	22,0	22,0	22,0
45	22,0	22,0	22,0	22,0	22,0	22,0	22,0
50	22,0	22,0	22,0	22,0	22,0	22,0	22,0
55	22,0	22,0	22,0	22,0	22,0	22,0	22,0
60	22,0	22,0	22,0	22,0	22,0	22,0	22,0
65	22,0	22,0	22,0	22,0	22,0	22,0	22,0
70	22,0	22,0	22,0	22,0	22,0	22,0	22,0
75	22,0	22,0	22,0	22,0	22,0	22,0	22,0
80	22,0	22,0	22,0	22,0	22,0	22,0	22,0
85	22,0	22,0	22,0	22,0	22,0	22,0	22,0
90	22,0	22,0	22,0	22,0	22,0	22,0	22,0
95	22,0	22,0	22,0	22,0	22,0	22,0	22,0
100	22,0	22,0	22,0	22,0	22,0	22,0	22,0
105	22,0	22,0	22,0	22,0	22,0	22,0	22,0
110	22,0	22,0	22,0	22,0	22,0	22,0	22,0
115	22,0	22,0	22,0	22,0	22,0	22,0	22,0
120	22,0	22,0	22,0	22,0	22,0	22,0	22,0
125	25,0	22,0	22,0	22,0	22,0	22,0	22,0
130	25,0	22,0	22,0	22,0	22,0	22,0	22,0
135	25,0	22,0	22,0	22,0	22,0	22,0	22,0
140	25,0	22,0	22,0	22,0	22,0	22,0	22,0
145	30,0	25,0	22,0	22,0	22,0	22,0	22,0
150	30,0	25,0	22,0	22,0	22,0	22,0	22,0
155	30,0	25,0	22,0	22,0	22,0	22,0	22,0
160	30,0	25,0	22,0	22,0	22,0	22,0	22,0
165	30,0	30,0	25,0	22,0	22,0	22,0	22,0
170	35,0	30,0	25,0	22,0	22,0	22,0	22,0
175	35,0	30,0	25,0	22,0	22,0	22,0	22,0
180	35,0	30,0	25,0	22,0	22,0	22,0	22,0
185	35,0	30,0	25,0	22,0	22,0	22,0	22,0
190	35,0	30,0	30,0	25,0	22,0	22,0	22,0
195	35,0	30,0	30,0	25,0	22,0	22,0	22,0
200	40,0	35,0	30,0	25,0	22,0	22,0	22,0
205	40,0	35,0	30,0	25,0	22,0	22,0	22,0
210	40,0	35,0	30,0	25,0	22,0	22,0	22,0
215	40,0	35,0	30,0	30,0	25,0	22,0	22,0
220	40,0	35,0	30,0	30,0	25,0	22,0	22,0
225	45,0	35,0	35,0	30,0	25,0	22,0	22,0
230	45,0	40,0	35,0	30,0	25,0	22,0	22,0
235	45,0	40,0	35,0	30,0	25,0	22,0	22,0
240	45,0	40,0	35,0	30,0	30,0	25,0	22,0
245	45,0	40,0	35,0	30,0	30,0	25,0	22,0
250	45,0	40,0	35,0	30,0	30,0	25,0	22,0
255	50,0	40,0	35,0	35,0	30,0	25,0	22,0
260	50,0	40,0	35,0	35,0	30,0	25,0	22,0
265	50,0	45,0	40,0	35,0	30,0	25,0	25,0
270	50,0	45,0	40,0	35,0	30,0	30,0	25,0
275	50,0	45,0	40,0	35,0	30,0	30,0	25,0
280	55,0	45,0	40,0	35,0	30,0	30,0	25,0
285	55,0	45,0	40,0	35,0	30,0	30,0	25,0
290	55,0	45,0	40,0	35,0	35,0	30,0	25,0
295	55,0	50,0	40,0	35,0	35,0	30,0	25,0
300	55,0	50,0	45,0	40,0	35,0	30,0	25,0
330	60,0	55,0	45,0	40,0	35,0	35,0	30,0
400			55,0	50,0	45,0	40,0	35,0

Table B.7 60 minutes fire resistance open profiles

90 minutes	Design temperature						
	350°C	400°C	450°C	500°C	550°C	600°C	650°C
Am/V	Minimum thicknesses [mm]						
40	22,0	22,0	22,0	22,0	22,0	22,0	22,0
45	22,0	22,0	22,0	22,0	22,0	22,0	22,0
50	22,0	22,0	22,0	22,0	22,0	22,0	22,0
55	22,0	22,0	22,0	22,0	22,0	22,0	22,0
60	22,0	22,0	22,0	22,0	22,0	22,0	22,0
65	22,0	22,0	22,0	22,0	22,0	22,0	22,0
70	22,0	22,0	22,0	22,0	22,0	22,0	22,0
75	25,0	22,0	22,0	22,0	22,0	22,0	22,0
80	25,0	22,0	22,0	22,0	22,0	22,0	22,0
85	30,0	25,0	22,0	22,0	22,0	22,0	22,0
90	30,0	25,0	22,0	22,0	22,0	22,0	22,0
95	30,0	30,0	25,0	22,0	22,0	22,0	22,0
100	35,0	30,0	25,0	22,0	22,0	22,0	22,0
105	35,0	30,0	25,0	22,0	22,0	22,0	22,0
110	35,0	30,0	30,0	25,0	22,0	22,0	22,0
115	40,0	35,0	30,0	25,0	22,0	22,0	22,0
120	40,0	35,0	30,0	30,0	25,0	22,0	22,0
125	40,0	35,0	30,0	30,0	25,0	22,0	22,0
130	45,0	40,0	35,0	30,0	25,0	22,0	22,0
135	45,0	40,0	35,0	30,0	30,0	25,0	22,0
140	45,0	40,0	35,0	30,0	30,0	25,0	22,0
145	50,0	40,0	35,0	35,0	30,0	25,0	22,0
150	50,0	45,0	40,0	35,0	30,0	30,0	25,0
155	50,0	45,0	40,0	35,0	30,0	30,0	25,0
160	55,0	45,0	40,0	35,0	30,0	30,0	25,0
165	55,0	45,0	40,0	35,0	35,0	30,0	25,0
170	55,0	50,0	45,0	40,0	35,0	30,0	30,0
175	60,0	50,0	45,0	40,0	35,0	30,0	30,0
180	60,0	50,0	45,0	40,0	35,0	35,0	30,0
185	60,0	55,0	45,0	40,0	35,0	35,0	30,0
190		55,0	50,0	45,0	40,0	35,0	30,0
195		55,0	50,0	45,0	40,0	35,0	30,0
200		55,0	50,0	45,0	40,0	35,0	35,0
205		60,0	50,0	45,0	40,0	35,0	35,0
210		60,0	55,0	45,0	40,0	40,0	35,0
215		60,0	55,0	50,0	45,0	40,0	35,0
220			55,0	50,0	45,0	40,0	35,0
225			55,0	50,0	45,0	40,0	35,0
230			55,0	50,0	45,0	40,0	35,0
235			60,0	50,0	45,0	40,0	40,0
240			60,0	55,0	50,0	45,0	40,0
245			60,0	55,0	50,0	45,0	40,0
250			60,0	55,0	50,0	45,0	40,0
255				55,0	50,0	45,0	40,0
260				55,0	50,0	45,0	40,0
265				60,0	50,0	45,0	45,0
270				60,0	55,0	50,0	45,0
275				60,0	55,0	50,0	45,0
280				60,0	55,0	50,0	45,0
285					55,0	50,0	45,0
290					55,0	50,0	45,0
295					60,0	50,0	45,0
300					60,0	55,0	50,0
330						60,0	50,0
400							

Table B.8 90 minutes fire resistance open profiles

120 minutes	Design temperature						
	350°C	400°C	450°C	500°C	550°C	600°C	650°C
Am/V	Minimum thicknesses [mm]						
40	22,0	22,0	22,0	22,0	22,0	22,0	22,0
45	22,0	22,0	22,0	22,0	22,0	22,0	22,0
50	25,0	22,0	22,0	22,0	22,0	22,0	22,0
55	30,0	22,0	22,0	22,0	22,0	22,0	22,0
60	30,0	25,0	22,0	22,0	22,0	22,0	22,0
65	35,0	30,0	25,0	22,0	22,0	22,0	22,0
70	35,0	30,0	25,0	22,0	22,0	22,0	22,0
75	40,0	35,0	30,0	25,0	22,0	22,0	22,0
80	40,0	35,0	30,0	25,0	25,0	22,0	22,0
85	40,0	35,0	35,0	30,0	25,0	22,0	22,0
90	45,0	40,0	35,0	30,0	30,0	25,0	22,0
95	45,0	40,0	35,0	30,0	30,0	25,0	22,0
100	50,0	45,0	40,0	35,0	30,0	30,0	25,0
105	50,0	45,0	40,0	35,0	30,0	30,0	25,0
110	55,0	45,0	40,0	35,0	35,0	30,0	25,0
115	55,0	50,0	45,0	40,0	35,0	30,0	30,0
120	60,0	50,0	45,0	40,0	35,0	35,0	30,0
125	60,0	55,0	45,0	40,0	40,0	35,0	30,0
130		55,0	50,0	45,0	40,0	35,0	30,0
135		55,0	50,0	45,0	40,0	35,0	35,0
140		60,0	50,0	45,0	40,0	40,0	35,0
145		60,0	55,0	50,0	45,0	40,0	35,0
150			55,0	50,0	45,0	40,0	35,0
155			60,0	50,0	45,0	40,0	40,0
160			60,0	55,0	50,0	45,0	40,0
165			60,0	55,0	50,0	45,0	40,0
170				55,0	50,0	45,0	40,0
175				60,0	50,0	45,0	40,0
180				60,0	55,0	50,0	45,0
185				60,0	55,0	50,0	45,0
190					55,0	50,0	45,0
195					60,0	50,0	45,0
200					60,0	55,0	50,0
205					60,0	55,0	50,0
210					60,0	55,0	50,0
215						55,0	50,0
220						60,0	55,0
225						60,0	55,0
230						60,0	55,0
235						60,0	55,0
240							55,0
245							60,0
250							60,0
255							60,0
260							60,0
265							
270							
275							
280							
285							
290							
295							
300							
330							
400							

Table B.9 120 minutes fire resistance open profiles

180 minutes	Design temperature						
	350°C	400°C	450°C	500°C	550°C	600°C	650°C
Am/V	Minimum thicknesses [mm]						
40	35,0	30,0	25,0	22,0	22,0	22,0	22,0
45	40,0	35,0	30,0	25,0	22,0	22,0	22,0
50	45,0	35,0	35,0	30,0	25,0	22,0	22,0
55	45,0	40,0	35,0	35,0	30,0	25,0	22,0
60	50,0	45,0	40,0	35,0	30,0	30,0	25,0
65	55,0	50,0	45,0	40,0	35,0	30,0	30,0
70	60,0	50,0	45,0	40,0	35,0	35,0	30,0
75		55,0	50,0	45,0	40,0	35,0	30,0
80		60,0	50,0	45,0	40,0	40,0	35,0
85			55,0	50,0	45,0	40,0	35,0
90			60,0	50,0	45,0	40,0	40,0
95			60,0	55,0	50,0	45,0	40,0
100				60,0	50,0	45,0	45,0
105				60,0	55,0	50,0	45,0
110					55,0	50,0	45,0
115					60,0	55,0	50,0
120					60,0	55,0	50,0
125						60,0	55,0
130						60,0	55,0
135							55,0
140							60,0
145							60,0
150							
155							
160							
165							
170							
175							
180							
185							
190							
195							
200							
205							
210							
215							
220							
225							
230							
235							
240							
245							
250							
255							
260							
265							
270							
275							
280							
285							
290							
295							
300							
330							
400							

Table B.10 180 minutes fire resistance open profiles